

# EZ-8-Methanol Pump

## STOP

**DO NOT RETURN  
THIS PRODUCT  
TO THE STORE!**

Please contact GPI before returning any product. If you are missing parts or experience problems with your installation, our Customer Support Department will be happy to assist you.

GPI Customer Support  
800-835-0113 or  
316-686-7361

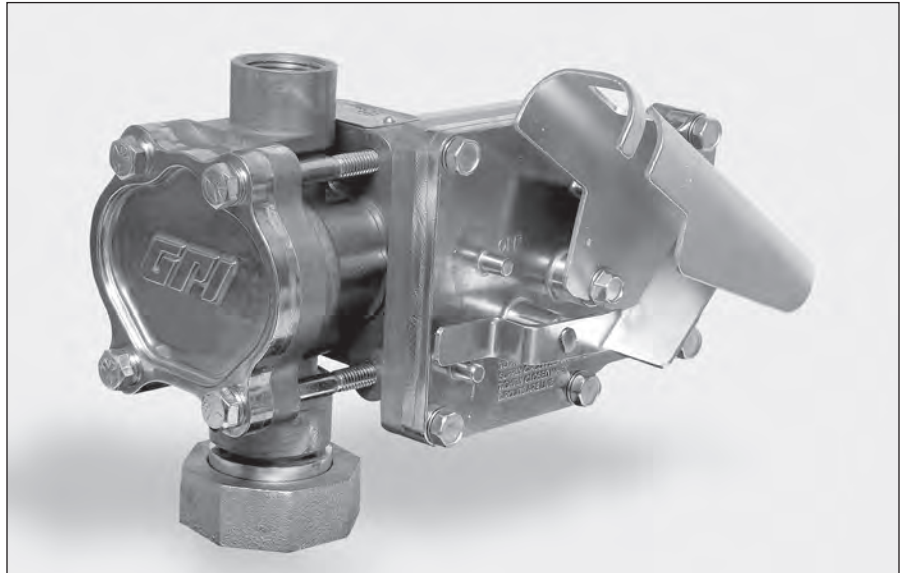

## GENERAL INFORMATION

These instructions will help you operate and maintain your pump. This owner's manual covers the EZ-8-Methanol, 12-Volt electric gear pump.

**Notice:** This pump is not intended to be used with an automatic nozzle.



**An automatic bypass valve prevents pressure build up when the pump is on with the nozzle closed. To avoid motor damage, do not run the pump more than 5 minutes with the nozzle closed.**

The rated duty cycle of this pump is 15 minutes ON and 30 minutes OFF. Allow the pump to cool for 30 minutes.

This pump is specifically designed for use with methanol and ethanol. The pump is also compatible with gasoline, diesel fuel (up to 20% biodiesel blends such as B20) and kerosene. **Do not** use this pump for dispensing any fluids other than those for which it was designed. To do so may damage pump components and will void the warranty.

This pump is designed to operate on a typical 12-volt DC automotive electrical system. The pump is designed to operate with 12-volts DC at the motor leads and the ratings are determined at this voltage. Performance may vary due to length of power cord, battery condition or output from vehicle charging system that will affect system voltage.

Do not leave the system running without fluids. "Dry running" can damage the pump. If the system fails to deliver fuel after 15 to 20 seconds, turn the system off and refer to the Troubleshooting Section.

Do not pump the tank completely dry, as contaminants from the bottom of the tank may enter the pump.

## SAFETY INSTRUCTIONS

Observe all safety precautions concerning safe handling of petroleum fuels.

To ensure safe operation, all fuel transfer systems must be properly grounded. Proper grounding means a continuous metal-to-metal contact from one component to the next, including tank, bung, pump, meter, filter, hose, and nozzle. Care should be taken to ensure proper grounding during initial installation and after any service or repair procedures. For your safety, please take a moment to review the warnings below.

To prevent physical injury, observe precautions against fire or explosion when dispensing fuel. Do not operate the system in the presence of any source of ignition including running or hot engines, lighted cigarettes, or gas or electric heaters.

Observe precautions against electrical shock when operating the system. Serious or fatal shock can result from operating electrical equipment in damp or wet locations.

Inspect external pump wiring regularly to make sure it is correctly attached to the battery. To avoid electrical shock, use extra care when connecting the pump to power.

Avoid prolonged skin contact with fuels. Use protective goggles, gloves, and aprons in case of splashing or spills. Change saturated clothing and wash skin promptly with soap and water.

Observe precautions against electrical shock when servicing the pump. **Always** disconnect power before repairing or servicing. **Never** apply electrical power to the system when any of the coverplates are removed.

If using solvent to clean pump components or tank, observe the solvent manufacturer's recommendations for safe use and disposal.

## INSTALLATION

This pump is designed to self-prime with dry gears.

Make sure all threaded fuel connections are wrapped with three to four turns of Teflon® tape or a pipe thread sealant approved for use with petroleum fuels.

Clean and bond the suction pipe top and bottom as necessary. Thread the suction pipe into the inlet fitting and tighten snugly. Trim the suction pipe as necessary to leave approximately 1/2 in. (1.2 cm) clearance from the bottom of the tank. Clean the tank interior of all dirt and debris. Insert the suction pipe into the tank opening. Tighten the pump onto the tank adapter. Do not cross thread.

Make sure the tank is vented. A vent cap rated at 3 psi or less is recommended.

### Install Electrical Connections

A grounding connection is provided. It is identified as a green colored binding head screw in the electrical cavity. Connect these pumps only to a 12-volt DC power source. Do not connect to a 24-volt DC, 115-volt AC or 230-volt AC power source.

For installation in unclassified areas, the supplied power cord, fuse and strain relief grip may be used.

**NOTE:** These components have not been evaluated as part of the UL Listed Equipment and are not intended for use in a Hazardous (Classified) Location.

To install the power cord, remove the electrical coverplate. If necessary, trim the power cord to the desired length. Strip 3 to 4 inches (7.5 to 10 cm) of outer insulation from the power cord end. Then strip 1/2 in. (1.3 cm) of insulation from the power cord wires. Slide the strain relief grip onto the power cord so that the threaded end of the strain relief grip faces the stripped power cord wires. Insert the power cord through the 1/2 inch NPT connection on the back of the pump. Using wire nuts, connect black wire to black and red wire to red in the pump's electrical cavity. Position the wires inside the electrical cavity and tighten the strain relief grip securely. Make sure surfaces are clean. Install the coverplate and tighten securely.

### ⚠ WARNING

Carefully route the power cord to the battery, protecting the power cord from hot surfaces, sharp edges or anything that could damage the power cord, resulting in a short circuit.

### ⚠ WARNING

A 20-amp fuse is provided to protect the motor and power cord. Install fuse in the red wire of the power cord adjacent to the battery. Connect the red wire of the fuse to the positive (ungrounded) side of the battery. Connect black wire to the negative (grounded) side of the battery.

### ⚠ DANGER

If pump is to be installed in a Hazardous (Classified) location, it must be installed by a licensed electrician and conform to National Fire Protection Association (NFPA) codes 30 and 70. You as the owner, are responsible for seeing that the installation and operation of your pump complies with NFPA codes as well as any applicable state and local codes. Rigid conduit must be used to install wiring. Note that the lead wires are factory-sealed isolating the motor from the junction box.

Failure to follow these wiring instructions may result in death or serious injury from shock, fire or explosion.

### Install Hose and Nozzle

After sealing threads, tighten the hose into the pump outlet and the nozzle on the hose. The nozzle can be placed in the nozzle holder only when the pump is off.

## OPERATION

**ALWAYS FOLLOW SAFETY PRECAUTIONS WHEN OPERATING THIS EQUIPMENT. REVIEW THE SAFETY INSTRUCTIONS.** Before each use, repair leaks around seals or connections. Make sure hoses are in good condition and connections are tight. Make sure the work area is dry. **MAKE SURE THE PUMP IS PROPERLY GROUNDED.** Repair any corroded or damaged wiring before use. Ensure the tank contains enough fuel. Make sure the fuel is not contaminated with debris. Tighten loose tank lids regularly.

### To Dispense Fuel

Turn on the pump by removing the nozzle from the holder and pushing up the switch lever. Insert the nozzle into the receiving tank and squeeze the handle to start fuel flow. When done, release the nozzle handle, turn the pump off, and return the nozzle to its holder.

This pump is designed to be self-priming. If fuel is not delivered within 15 to 20 seconds, turn the pump off and refer to priming information in the Troubleshooting Section.

An automatic bypass valve prevents pressure build up when the pump is on with the nozzle closed. To avoid pump damage, do not run the pump more than 5 minutes with the nozzle closed.

After running the pump for a maximum of 15 minutes, allow it to cool for 30 minutes.

### Auxiliary Temperature-Limiting Device

The motor is provided with an internal auxiliary temperature-limiting device. Excessive motor heat can trip the device. It resets automatically after the motor has cooled.

## MAINTENANCE

This pump is designed for minimum maintenance. Motor bearings are sealed and require no lubrication. Inspect the pump and components regularly for fuel leaks and make sure the hose and power cord are in good condition. Keep the pump exterior clean to help identify leaks.

Do not use this pump for water, chemicals or herbicides. Dispensing any fluid other than that listed in this manual will damage the pump. Use of the pump with unauthorized fluids will void the warranty.

## TROUBLESHOOTING

**ALWAYS DISCONNECT POWER BEFORE REPAIRING OR SERVICING THE PUMP. NEVER APPLY POWER TO THE SYSTEM WHEN ANY COVERPLATE IS REMOVED.**

### A. MOTOR DOES NOT RUN

1. **Auxiliary temperature-limiting device tripped.** Turn pump switch off. Allow motor to cool. Device resets automatically. Try again.
2. **Switch defective.** Remove electrical coverplate and inspect switch. Replace if necessary.
3. **Motor burned out.** Inspect and replace as necessary.
4. **Switch or electrical connection faulty.** Inspect for defective wiring or switch, or improper electrical connections. Replace as necessary.
5. **Fuse blown.** Inspect fuse in fuse holder. If blown, replace.

### B. MOTOR RUNS BUT DOES NOT PUMP FLUID

1. **Suction pipe clogged, damaged, or missing.** Remove pump from tank. Inspect suction pipe. Clean or replace, as necessary.
2. **Gear coverplate or O-ring damaged.** Remove and inspect the coverplate and O-ring. Replace as necessary.
3. **Strainer clogged or defective.** Inspect and clean as required.
4. **Bypass poppet O-ring worn, missing or dirty.** Inspect the O-ring. Replace as necessary.
5. **Bypass poppet binding or damaged.** Remove the bypass poppet, spring, and O-ring. Clean cavity. Inspect and replace as necessary.
6. **System air leak.** Tighten all pump fittings and connections. Inspect suction pipe for leaks or damage.
7. **Poor connections or low voltage.** Make sure electrical connections are secure. Also check battery voltage.
8. **Fuel level low.** Fill tank.
9. **Motor running backwards due to incorrect polarity.** Connect red wire to positive (+) ungrounded side of battery.

### C. LOW FLOWRATE

1. **Poor connections or low voltage.** Make sure electrical connections are secure. Also check battery voltage.
2. **Strainer partially clogged.** Inspect and clean as required.
3. **Suction pipe clogged or damaged.** Remove pump from tank. Inspect suction pipe. Clean or replace.
4. **Fuel tank empty.** Fill tank.
5. **System air leak.** Tighten all pump fittings and connections. Inspect suction pipe for leaks or damage. Replace as necessary.
6. **Suction pipe too close to tank bottom.** Suction pipe must have at least 1/2 in. (1.2 cm) clearance from bottom of tank.

### D. MOTOR STALLS WHEN OPERATING IN BYPASS MODE

1. **Gears locked.** Remove gear coverplate and inspect gears and drive key. Make sure gears turn freely with the key removed. Replace, if worn.
2. **Wiring defective.** Use instructions in the Installation Section to ensure proper electrical connections.
3. **Bypass poppet binding or damaged.** Remove the bypass poppet, spring, and O-ring. Clean cavity. Inspect components and replace as necessary.
4. **Motor defective.** Inspect and replace as necessary.

### E. SWITCH FAILS TO OPERATE MOTOR

1. **Motor burned out.** Inspect and replace as necessary.
2. **Switch or electrical connections faulty.** Inspect for blown fuse, defective wiring or switch, or improper electrical connections. Replace as necessary.

### F. RAPID OVERHEATING OF MOTOR

1. **Duty cycle too long.** Pump operation should not exceed the standard duty cycle of 15 minutes on and 30 minutes off. Allow the pump to cool for 30 minutes.

2. **Strainer clogged.** Inspect and clean as required.
3. **Suction pipe clogged or damaged.** Remove pump from tank. Inspect suction pipe. Clean or replace as necessary.
4. **Fuel level low.** Fill tank.
5. **Running too long in bypass mode.** Limit bypass operation to 5 minutes.

## SPECIFICATIONS

### Applications:

The EZ-8-Methanol Pump is specifically designed for use with methanol and ethanol. The pump is also compatible with gasoline, diesel fuel (up to 20% biodiesel blends such as B20) and kerosene. The pump is designed for permanent mounting on vented storage tanks.

### Pump Housing:

Lightweight, corrosion-resistant, nickel plated, cast aluminum body.

### Performance:

Pump Rate: Up to 8 GPM (30 LPM)  
Duty Cycle: 15 min. ON, 30 min. OFF  
Suction Lift: Manual nozzle: Up to 5.5 ft. (1.7 m)

### Operating Temperature:

-20°F to +125°F (-29°C to +52°C)

### Operating Pressure: 15 PSI

### Electrical Specifications:

Input: 12-volt DC  
Current Draw: 11 amp  
Motor: 2100 RPM, UL Listed to UL and Canadian Standards  
1/10 HP (75 watts)

### Mechanical Connections:

Bung: 2 in. NPT Inlet: 3/4 in. NPT Outlet: 3/4 in. NPT

### Accessories:

Cord: 15 ft. (4.6 m) of 14/2 gauge  
Fuse: 20 amp  
Strain Relief Grip

### Shipping Weight: 9.0 lbs. (4.1 kg)

## PARTS AND SERVICE

In order to preserve the UL Listing for the motor, do not attempt to service the motor. For products serviced outside the factory, the UL nameplate must be defaced to indicate that the equipment may no longer meet the requirements for UL Listing. This does not apply to products serviced outside the factory under the UL program for Rebuilt Motors for Use in Hazardous Locations.

For warranty consideration, parts, or other service information, please contact your local distributor or the GPI Customer Service Department in Wichita, Kansas, during normal business hours at:

**1-800-835-0113**

To obtain prompt, efficient service, always be prepared with the model number of your pump, the serial number or manufacturing date code of your pump, and part descriptions and numbers.

For warranty work, always be prepared with your original sales slip or other evidence of purchase date.

Please contact GPI before returning any parts. GPI can inform you of special requirements you will need to follow.

**CAUTION:** Do not return the pump or parts without authority from the Customer Service Department. Due to strict government regulations, GPI cannot accept parts unless they have been drained and cleaned.

# ILLUSTRATED PARTS LIST

Item No.	Part No.	Description	No. Req'd.
1	137041-01	Motor, 12 volt .....	1
2	904004-2	Screw, Hex Head Cap.....	4
3	110025-1	Motor Shaft Seal .....	1
4	137031-01	Bypass Poppet .....	1
5	137039-06	Spring, Bypass Poppet.....	1
6	901003-76	O-Ring.....	1
7	123038-1	Inlet Strainer.....	1
8	901003-70	O-Ring.....	1
9	137014-01	Switch Coverplate.....	1
11	902007-30	Switch .....	1
12	110360-02	Nozzle Cover.....	1
13	904006-86	Tapping Screw .....	2
14	904002-23	Sems Screw.....	6
15	904007-65	Washer, Flat .....	4
16	137007-01	Switch Lever Assembly.....	1
17	110017-2	Drive Key.....	1
18	90100401	O-Ring.....	1

Item No.	Part No.	Description	No. Req'd.
19	137012-02	Gear Coverplate, ENP.....	1
20	137010-04	Pump Housing, ENP .....	1
21	13706702	Inlet Fitting, ENP .....	1
22	110158-1	Union Ring .....	1
23	110037-1	Bushing, Tank Bung Adapter .....	1
Items not shown			
	904002-17	Strain Relief Sealing Grip .....	1
	110412-15	Power Cord, 14 ga. x 15 ft. (4.6 m).....	1
	13703002	Suction Pipe.....	1
	906001-4	Pressure Vent Cap (3 psi).....	1
	13750003	Gear Kit (includes 2 gears, drive key) .....	1
	13750006	Drive Key Kit (includes drive key).....	1
	13750001	Fuse Holder Kit (includes fuse holder, fuse, wire).....	1

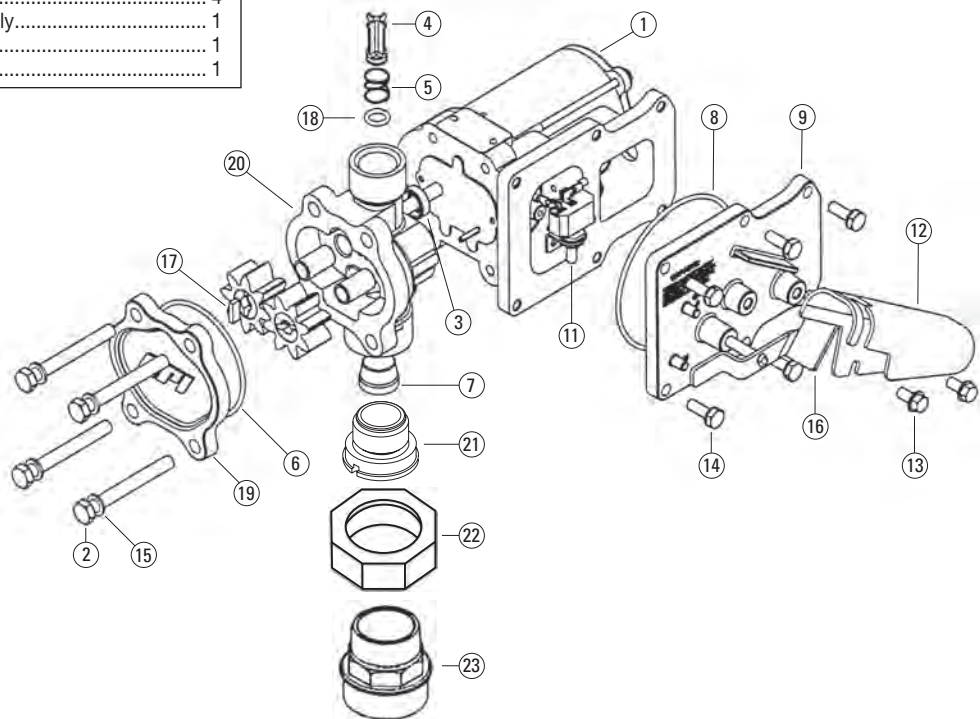

### Limited Warranty Policy

Great Plains Industries, Inc. 5252 E. 36<sup>th</sup> Street North, Wichita, KS USA 67220-3205, hereby provides a limited warranty against defects in material and workmanship on all products manufactured by Great Plains Industries, Inc. This product includes a 2 year warranty from date of purchase as evidenced by the original sales receipt. A 30 month warranty from product date of manufacture will apply in cases where the original sales receipt is not available. Reference product labeling for the warranty expiration date based on 30 months from date of manufacture. Manufacturer's sole obligation under the foregoing warranties will be limited to either, at Manufacturer's option, replacing or repairing defective Goods (subject to limitations hereinafter provided) or refunding the purchase price for such Goods theretofore paid by the Buyer, and Buyer's exclusive remedy for breach of any such warranties will be enforcement of such obligations of Manufacturer. The warranty shall extend to the purchaser of this product and to any person to whom such product is transferred during the warranty period.

This warranty shall not apply if:

- A. the product has been altered or modified outside the warrantor's duly appointed representative;
- B. the product has been subjected to neglect, misuse, abuse or damage or has been installed or operated other than in accordance with the manufacturer's operating instructions.

To make a claim against this warranty, contact the GPI Customer Service Department at 316-686-7361 or 800-835-0113. Or by mail at:

Great Plains Industries, Inc.  
5252 E. 36<sup>th</sup> St. North  
Wichita, KS, USA 67220-3205

GPI will step you through a product troubleshooting process to determine appropriate corrective actions.

**GREAT PLAINS INDUSTRIES, INC., EXCLUDES LIABILITY UNDER THIS WARRANTY FOR DIRECT, INDIRECT, INCIDENTAL AND CONSEQUENTIAL DAMAGES INCURRED IN THE USE OR LOSS OF USE OF THE PRODUCT WARRANTED HEREUNDER.**

The company herewith expressly disclaims any warranty of merchantability or fitness for any particular purpose other than for which it was designed.

This warranty gives you specific rights and you may also have other rights which vary from U.S. state to U.S. state.

Note: In compliance with MAGNUSON MOSS CONSUMER WARRANTY ACT - Part 702 (governs the resale availability of the warranty terms).



**ELECTRIC MOTOR FOR  
HAZARDOUS LOCATIONS**



5252 East 36th Street North  
Wichita, KS USA 67220-3205  
TEL: 316-686-7361  
FAX: 316-686-6746

**GREAT PLAINS INDUSTRIES, INC.**

"A Great Plains Ventures Subsidiary"

www.gpipumps.net

**1-800-835-0113**

GPI and the electric gear pump are registered trademarks of Great Plains Industries, Inc. U.S. Design Patent D543,217

© 2009 GREAT PLAINS INDUSTRIES, INC., Wichita, KS  
Printed in U.S.A. 09/09

Rev. - 92182001