

MS85G
0603
0004

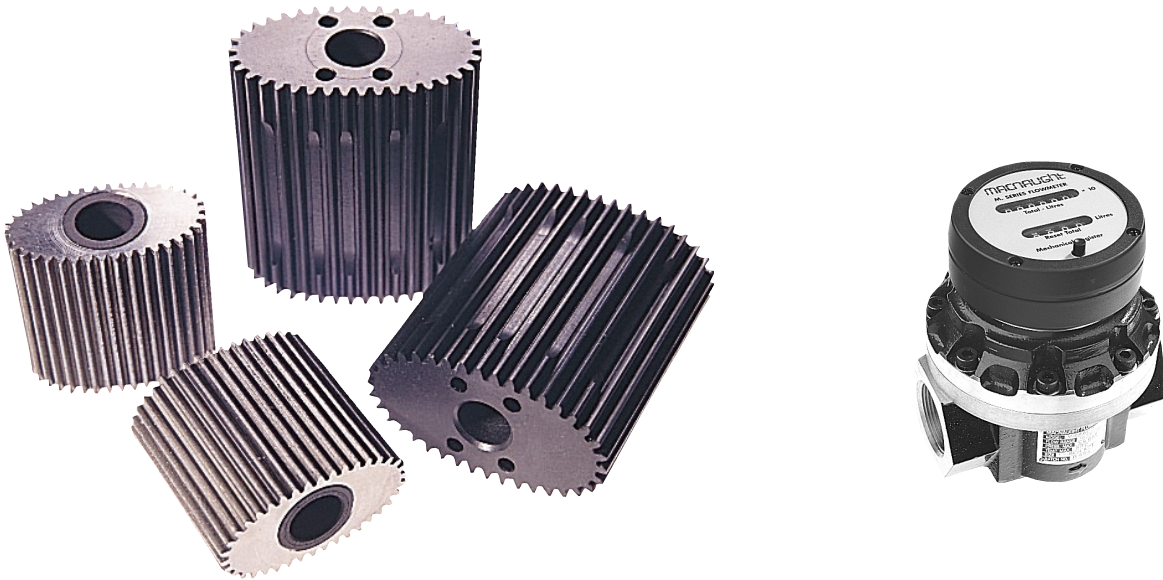

GREAT PLAINS INDUSTRIES, INC.

Positive Displacement Flowmeters
— GM510 series instruction manual —



GM510 Mechanical Meter • From serial No. CXXXX

To the owner

Thank you for purchasing a GPI GM Series Flow Meter. Please take a few minutes to read through this manual before installing and operating your meter. If you have any problems with the meter, refer to the maintenance and trouble shooting sections of this manual.

This manual contains connection and operating instructions for the GM510 Series meters with mechanical displays. If you need further assistance, contact your local GPI representative

or contact GPI by telephone or fax for advice.

The GPI GM Series Flow Meter has incorporated the oval rotor principal into its design. This has proven to be a reliable and highly accurate method of measuring flow. Exceptional repeatability and high accuracy over a wide range of fluid viscosities and flow rates are features of the GM Series flow meter design. The low pressure drop and high pressure rating means the GM Series flow meter is suitable for both

gravity and pump (in line) applications.

The GPI GM Series flow meters are available in either aluminium, Bronze or 316 stainless steel. Standard rotors are made from PPS (Polyphenylene Sulfide Resins) with optional 316 stainless steel rotors available for both stainless steel and aluminium models.

The GM510 Series mechanical displays have a resettable batch totaliser and non-resettable accumulative totaliser.

Important Information



PLEASE READ THIS INFORMATION CAREFULLY BEFORE USE!

Before use, confirm the fluid to be used is compatible with the meter (refer to the GPI fluid compatibility chart), or consult your local GPI representative for advice.

To prevent damage from dirt or foreign matter, GPI recommends a Y or Basket type 60 mesh strainer be installed as close as possible to the inlet side of the meter (if required contact GPI for further information).

Note: When a strainer is installed it should be regularly inspected and cleaned. Failure to keep the strainer clean will dramatically effect flow meter performance.

To prevent damage to the meter slowly fill the system with fluid (this will prevent damage caused by air purge).

Note: Failure to do this could damage the meter.

For pump applications, turn off the pump at the end of each day.

Installation

1] GPI recommends that when setting up pipework for meter installations a bypass line be included in the design. This provides the facility for a meter to be removed for maintenance without interrupting production. (See Fig.1)

orientation as long as the meter shafts are in a horizontal plane. (Refer to Fig.2 for correct installation) The register assembly may be orientated to suit the individual installation.

Note: Incorrect installation can cause premature wear of meter components.

2] Use thread sealant on all pipe threads. For flanged versions 1" ANSI 150lb or DIN16, appropriate companion flanges and gaskets are required.

7] Do not over tighten meter connections.

3] For pump applications ensure pipe work has the appropriate working pressure rating to match the pressure output of the pump.

8] It is important that after initial installation you fill the line slowly, high speed air purge could cause damage to the rotors.

4] Install a wire mesh strainer (Y or basket type 60 mesh as close as possible to the inlet side of the meter.

9] Test the system for leaks.

5] Ensure that the meter is installed so that the flow of the liquid is in the direction of the arrows embossed on the meter body.

10] Check the strainer for swarf or foreign material, after the first 200 litres check periodically, particularly if the flow rate decreases.

6] The meter can be installed in any

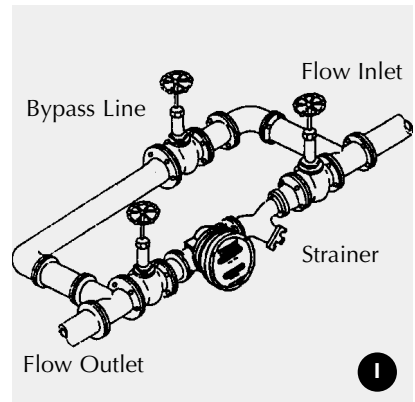

Operation

When fluid passes through the meter, rotors turn. The gear located on top of one of the rotors drives the mechanical registers gear train which provides an accurate readout.

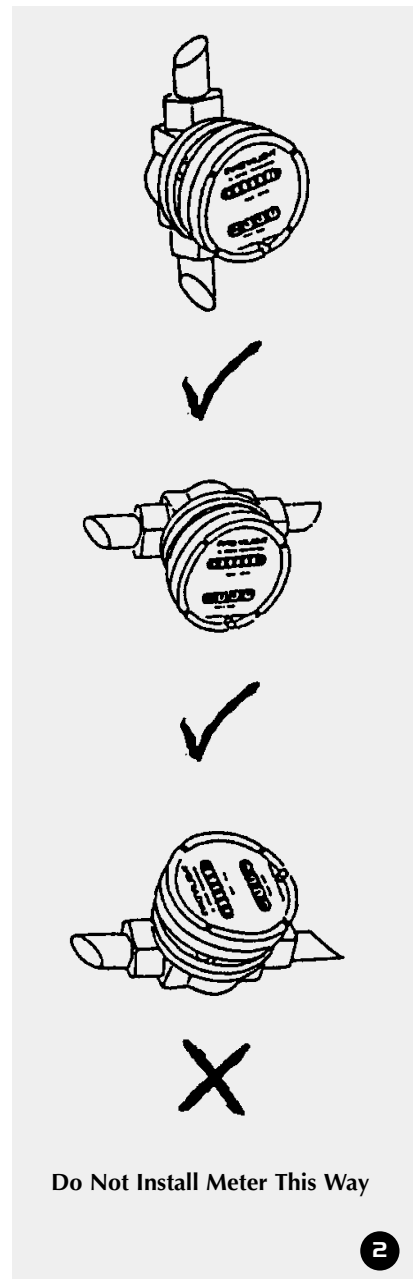
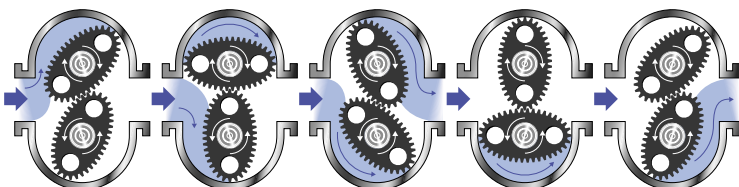

Service Instructions

Disassembly

Ensure that the fluid supply to the meter is disconnected, and the line pressure is released before disassembly. Refer to the exploded parts diagram on pages 5 and 6 for item numbers.

- 1] Remove the four screws (Item 17) located on the face of the register. Then remove the face plate cover including register assembly.
- 2] Remove the four register mounting screws (Item 15). Then remove the lower half of the register housing.
- 3] Remove the six cover plate screws (Item 12) and remove the cover plate (Item 11).
- 4] Remove the six meter cap screws (Item 5) and remove the meter cap (Item 4).
- 5] Remove rotors (Item 3).

Reassembly

- 1] Clean all components before reassembly.
- 2] Before reassembly check the condition of the rotors (Item 3). Replace if necessary.
- 3] Replace the rotor (with the gear) on the short shaft in the housing then place the 2nd rotor onto the shaft so as the rotors are at 90° to each other. (Refer Fig 3). Check rotor operation by turning either of the rotors. If the rotors are not in mesh correctly or do not move freely remove one of the rotors and

replace it correctly at 90° to the other rotor. Recheck the operation of the rotors.

- 4] Inspect the gears (Item 6) in the meter cap (Item 4) for wear. (Replace if required, refer to spare parts on page 10).
- 5] Replace the o-ring (Item 2) into the groove in the meter cap, if the o-ring has been distorted or is damaged in any way replace it with a new part.
- 6] Replace the meter cap, making sure the locating pins line up with the holes in the meter cap and the gear on the rotor meshes correctly with the gear in the meter cap (Item 4). Insert the allen screws (Item 5) and tighten in the sequence 1, 4, 2, 5, 3, 6.
- 7] Inspect the bevel gear (Item 13), o-ring (Item 10), and output gear (Item 7) for wear or damage. (Replace faulty components if necessary).
- 8] Replacement of output shaft, bush and seal.

Disassembly

- a. Remove the bevel gear.
- b. Remove the circlip and push out the output shaft assembly, including washer.
- c. Remove the seal.
- d. Carefully press out the output shaft bush (If required).

Assembly

- a. Carefully press the new output shaft bush into place (Use Loctite Primer 747, as per instructions,

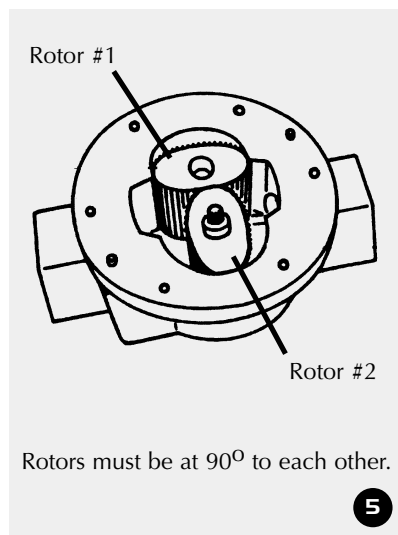

followed by sealant Loctite 262).

b. Insert a new seal into the groove of the output shaft bush.

c. Replace the output gear and washer and replace the circlip to lock the output gear shaft into place.

d. Replace the bevel gear (Item 13) and tighten the grub screw onto flat face of shaft.

- 9] Place the o-ring (Item 10) into the groove in the cover plate (Replace the o-ring seal if required).
- 10] Place the cover plate onto the meter. Replace the cover plate screws and tighten the six cap head screws (Item 12) firmly.
- 11] Place the lower cover plate of the register into position. Replace the four screws (Item 15) and tighten.
- 12] Position the register correctly on top of the lower register cover. Replace the four screws (Item 17) and tighten.
- 13] Test the meter by turning the rotors with a finger or by applying low air pressure (No more than a good breath) to one end of the meter, before returning meter to the line.

Meter Trouble Shooting

TROUBLE SHOOTING GUIDE		
TROUBLE	CAUSE	REMEDY
Fluid will not flow through meter	<ul style="list-style-type: none"> a] Foreign matter blocking rotors b] Line strainer blocked c] Damaged rotors d] Meter connections over tightened e] Fluid is too viscous 	<ul style="list-style-type: none"> a] Dismantle meter, clean rotors (Strainer must be fitted in line) b] Clean strainer c] Replace rotors (Strainer must be fitted in line) d] Re-adjust connections e] See specifications for maximum viscosity
Reduced flow through the meter	<ul style="list-style-type: none"> a] Strainer is partially blocked b] Fluid is too viscous 	<ul style="list-style-type: none"> a] Clean strainer b] See specifications for maximum viscosity
Meter reading inaccurate	<ul style="list-style-type: none"> a] Fluid flow rate is too high or too low b] Fluid is too viscous c] Excess wear caused by incorrect installation 	<ul style="list-style-type: none"> a] See "specifications" for minimum and maximum flow rates b] Bleed air from system c] Check meter body and rotors. Replace as required. Refer to installation instructions
Fluid flows but no reading on meter	<ul style="list-style-type: none"> a] Bevel gear is loose on shaft b] Rotor drive gear is damaged c] Transmission gears damaged d] Register gears damaged 	<ul style="list-style-type: none"> a] Tighten grub screws b] Replace rotor c] Replace gears d] Replace register assembly
Fluid leaks into register	<ul style="list-style-type: none"> a] Seal won or damaged on the cover plate 	<ul style="list-style-type: none"> a] Replace seal (Check seal compatibility with fluid)

Meter Parts Listing

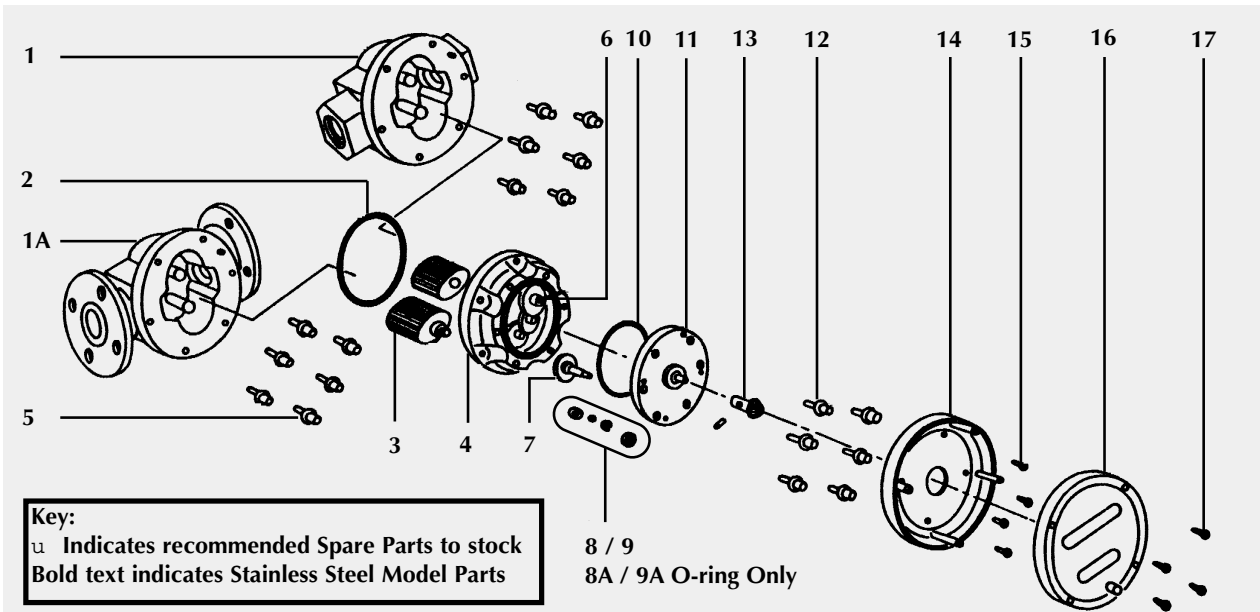

Item No.	No. Off.	Rec. Parts	Part or Set (Order from this column only)	Part Description
1	1		MS188B	Meter Body 1" BSP (Aluminium)
1	1		MS188N	Meter Body 1" NPT (Aluminium)
1	1		MS186B	Meter Body 1" BSP (Stainless Steel)
1	1		MS186N	Meter Body 1" NPT (Stainless Steel)
1	1		MS188F	Meter Body 1" ANSI 150lb Flange (Aluminium)
1	1		MS188D	Meter Body 1" DIN16 Flange (Aluminium)
1	1		MS186F	Meter Body 1" ANSI 150lb Flange (S/Steel)
1	1		MS186D	Meter Body 1" DIN16 Flange (S/Steel)
2	1	u	BS235TES	"O" Ring (Teflon)
2	1	u	BS235VS	"O" Ring (Viton)
3	2	u	MS72S	Rotors PPS (Polyphenylene Sulfide Resins) brass hub
3	2	u	MS72-1HS	High Viscosity Rotors (SS) with Stainless Steel hub
3	2	u	MS72-1S	Rotors SS (Stainless Steel hub)
3	2	u	MS72-2S	Rotors PPS (with Stainless Steel hub)
3	2	u	MS72HS	High Viscosity Rotors (PPS)
3	2	u	MS72HS-2S	High Viscosity Rotors (PPS) S/Steel hub
4	1		MS75S	Meter Cap Liters (Aluminium)
4	1		MS75US	Meter Cap US Gallons (Aluminium)
4	1		MS251S	Meter Cap Liters (Stainless Steel)
4	1		MS251US	Meter Cap US Gallons (Stainless Steel)
5	6	u	MS114S	Meter Cap Screws (Standard)
5	6	u	MS200S	Meter Cap Screws (Stainless Steel)
6	1	u	MS294S	Complete Gear Set - Liters
6	1	u	MS316S	Complete Gear Set - US Gallons
7	1	u	MS77S	Output Gear & Shaft Assembly
8	1	u	MS78VS	Coverplate Seal/Bush Set Viton
8A	1	u	OR42C	Solvent o-ring (Perfluoro Elastomer)
9	1	u	MS78C	Coverplate Seal/Bush Set Solvent
9A	1	u	V7-007S	O-ring Viton

Meter Parts Listing

Item No.	No. Off.	Rec. Parts	Part or Set (Order from this column only)	Part Description
10	1	u	BS145TES	O-ring (Teflon)
10	1	u	BS145VS	O-ring (Viton)
11	1		MS99S	Coverplate (Aluminium) includes bush
11	1		MS99-1S	Coverplate (Stainless Steel) includes bush
12	6	u	MS312S	Coverplate Screws
12	6	u	MS313S	Coverplate Screws (Stainless Steel)
13	1	u	MS83S	Bevel Gear Set
14	1		MS140	Bottom Register Coverplate
15	4	u	MS111S	Mounting Screws
16	1	u	MS141S	Register Assembly with Coverplate - Liters
16	1	u	MS141US	Register Assembly with Coverplate - US Gallons
17	4	u	MS129S	Register Body Screws
18	1		Customer to specify model	Legend Plate (Not Pictured) includes Hammer Screws
19	1		MS37	Warning Label (Not Pictured)

Note: Complete Register Assembly Part Numbers; "Liter" Register - MS84, "US Gallons" Register - MS84U

Meter Dimensions

Mechanical Meter Dimensions

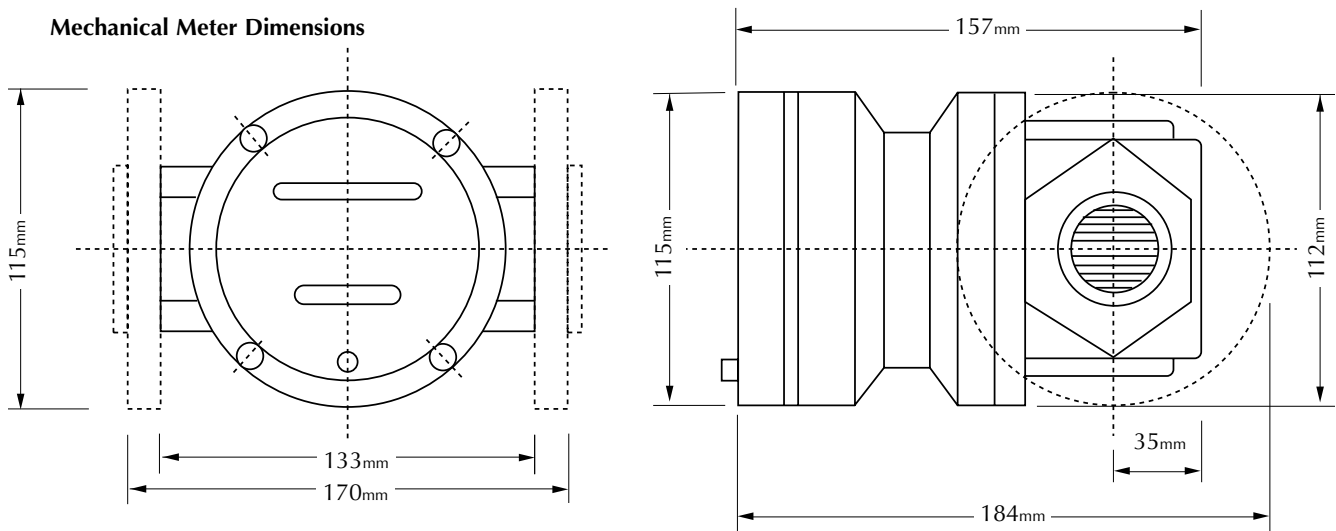

Meter Specifications

Flow Ranges

(Liter per minute/US Gallons per minute)

Above 5 Centipoise 6 to 120/ 1.6 to 32

Below 5 Centipoise 10 to 100/ 2.6 to 26

Accuracy of Reading +/- 1%

Maximum Viscosity* 1000 Centipoise

Maximum Operating Pressure 3450 kPa / 500 PSI / 34.5 BAR

Maximum Operating Temperature 80°C / 176°F (Stainless Steel Models 120°C / 248°F)

* Unless High Viscosity Rotors are fitted

Warranty

Great Plains Industries, Inc. Limited Warranty Policy

Great Plains Industries, Inc., 5252 East 36th Street North, Wichita, Kansas USA 67220-3202, hereby provides a limited one year warranty against defects in material and workmanship on all products manufactured by Great Plains Industries, Inc. This warranty shall extend to the purchaser of this product and to any person to whom such product is transferred during the warranty period.

The warranty period shall begin on the date of the original new equipment purchase. Warrantor's obligation hereunder shall be limited to repairing defective workmanship or replacing or repairing any defective part or parts. This warranty shall not apply if:

- a.) the product has been altered or modified outside the warrantor's duly appointed representative;
- b.) the product has been subjected to neglect, misuse, abuse or damage or has been installed or operated other than in accordance with the manufacturer's operating instructions.

To make a claim against this warranty, notice of claim must be given in writing to the company at its above address no later than 30 days after the expiration of the warranty period. Such notice shall identify the defect in the product. The company shall, within 14 days of receipt of such notice, notify the customer to either send the product, transportation prepaid, to the company at its office in Wichita, Kansas, or to duly authorized service center. The company shall perform all obligations imposed on it by the terms of this warranty within 60 days of receipt of the defective product.

GREAT PLAINS INDUSTRIES, INC. EXCLUDES LIABILITY UNDER THIS WARRANTY FOR DIRECT, INDIRECT, INCIDENTAL AND CONSEQUENTIAL DAMAGES INCURRED IN THE USE OR LOSS OF USE IF THE PRODUCT WARRANTED HEREUNDER.

The company herewith expressly disclaims any warranty of merchantability or fitness for any particular purpose other than for which it was designed.

This warranty gives you specific rights and you may also have other rights which vary from U.S. state to U.S. state.

NOTE: In compliance with MAGNUSON MOSS CONSUMER WARRANTY ACT - Part 702 (governs the resale availability of the warranty terms).



5252 East 36th Street North
Wichita, KS USA 67220-3205
TEL: 316-686-7361
FAX: 316-686-6746
